

# INSTRUCTION MANUAL



**KEPCO** An ISO 9001 Company.

**KIT  
DIN RKW  
-150S**

## DIN-RAIL MOUNTING KIT FOR SERIES RKW 150W

**DESCRIPTION.** Kepco KITS, Models DIN RKW-150S, contains two preassembled mounting clips and associated hardware used to install RKW 150 Watt Series power supplies on a DIN rail. The "S" suffix is for mounting along the short dimension (width) as shown in Figure 1. Outline dimensions are shown in Figure 4

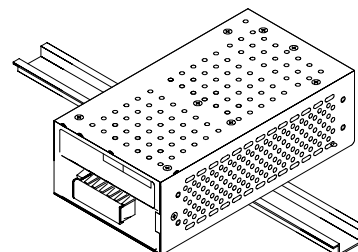

3042689

**FIGURE 1. S SUFFIX ORIENTATION**

**TABLE 1. COMPONENTS SUPPLIED**

KIT MODEL NO.	COVER PART NO.	MOUNTING PLATE (QTY 2) PART NO.F	CLIP (QTY 2) PART NO.	SCREW (QTY 4) PART NO.	WASHER (QTY 4) PART NO.
DIN RKW-150S	CA 36	128-2125	108-0362	501-0075 (M4 X 8 BN FHPH)	103-0017 (NO. 8, INT. TOOTH)

**INSTALL COVER.** Attach the cover to the power supply per instruction manual supplied with the cover.

**INSTALLING KIT.** Attach the preassembled mounting clips to the power supply using the hardware supplied (see Figure 3). The clips may be mounted with the release lever on either side to facilitate removal.

**INSTALLING POWER SUPPLY ON DIN RAIL.** To mount the power supply on the rail insert one end of both clamps under one edge of the rail, then snap the other end of the two clips into place (see Figure 2A).

**REMOVING POWER SUPPLY FROM DIN RAIL.** While grasping the power supply with one hand, use a screwdriver to apply leverage towards the left as shown in Figure 2B to disengage each clip from the rail. Where mounting clips are close together, it may be necessary to apply leverage with two screwdrivers simultaneously.

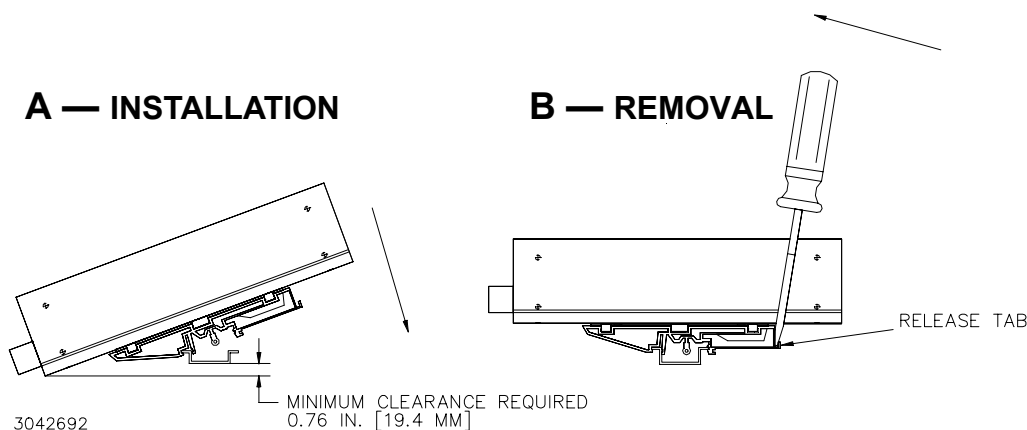

**FIGURE 2. INSTALLATION AND REMOVAL OF POWER SUPPLY FROM DIN RAIL**

KEPCO, INC. ● 131-38 SANFORD AVENUE ● FLUSHING, NY. 11352 U.S.A. ● TEL (718) 461-7000 ● FAX (718) 767-1102

<http://www.kepcopower.com> ● email: [hq@kepcopower.com](mailto:hq@kepcopower.com)

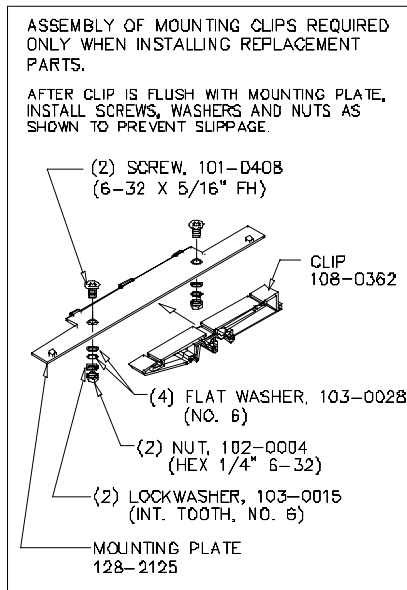

3042890

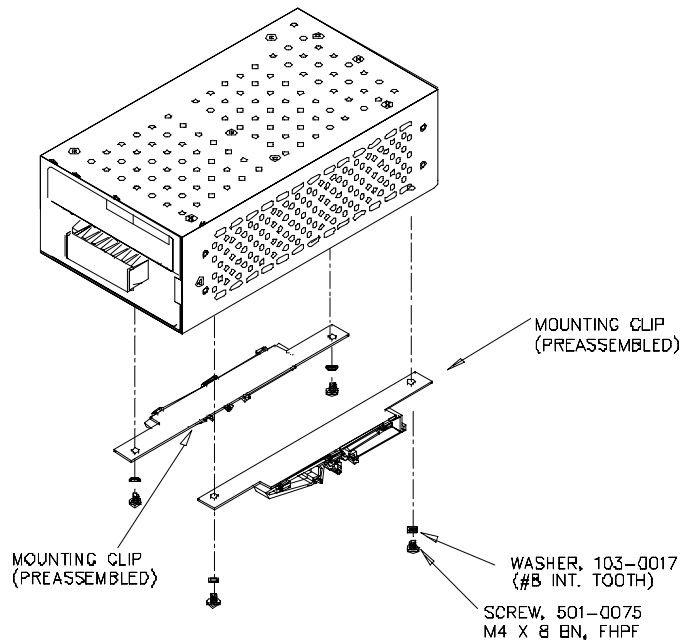
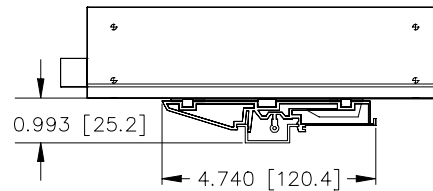
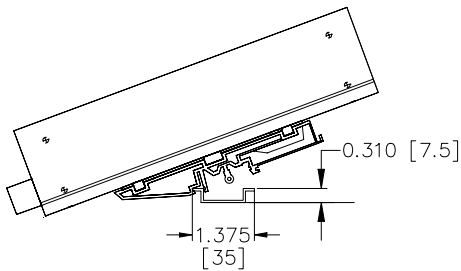
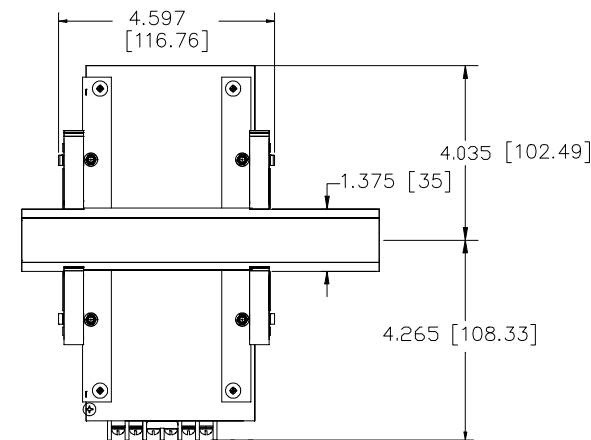

FIGURE 3. INSTALLATION OF KIT ON RKW POWER SUPPLY



3042691

NOTE: DIMENSIONS ARE IN INCHES. DIMENSIONS IN BRACKETS ARE IN MILLIMETERS.

FIGURE 4. RKW 150W POWER SUPPLY WITH KIT INSTALLED, OUTLINE DIMENSIONS